

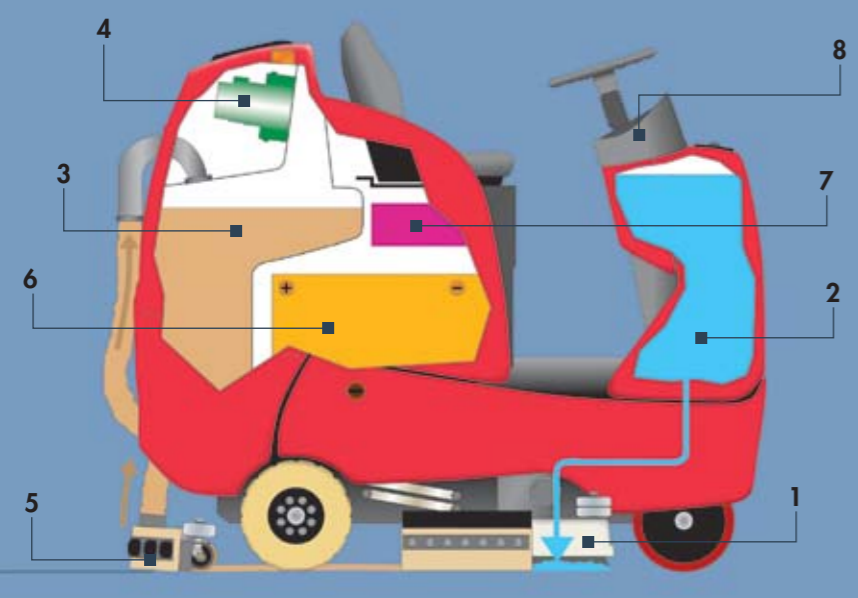

Cleans large areas in a flash!

JUMBO

JUMBO is a compact scrubber-drier with a performance equal to bigger machines. It has a scrubbing width of 80 or 95 cm or it can sweep and scrub at the same time with an 86 cm width. Although the tank dimensions appear very small (185 cm long x 80 cm wide) it has a 180 litre detergent tank and a 195 litre recovery tank; it can be equipped with a 360A battery for longer working performance. JUMBO has been modelled on the reliable DRIVE and can effortlessly clean large open areas and restrictive spaces, as if it is flying! JUMBO is the ideal scrubber-drier for those who need efficiency, longer working time and working profitability.



Operating Diagrams

- 1 - Brush head
- 2 - Solution tank
- 3 - Recovery tank
- 4 - Vacuum motor
- 5 - Squeegee
- 6 - Batteries
- 7 - Electronic system
- 8 - Control board

Optional

- 1 - black pad*
- 2 - red pad*
- 3 - driving disc*
- 4 - TYNEX brush*
- 5 - PPL brush*
- 6 - TYNEX roller brush**
- 7 - PPL roller brush**
- 8 - brush connection*
- 9 - traction battery 6V-180A (5h)
- 10 - traction battery 36V-360A (5h)
- 11 - polyurethane squeegee rubber
- 12 - battery charger 36V-25A
- 13 - battery charger 36V-40A
- 14 - polyurethane rear wheels
- 15 - kit for 6V batteries

* only for models 812 and 962
** only for model 872 R

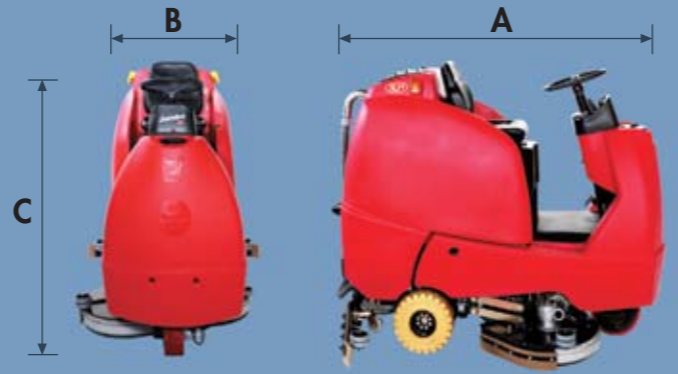
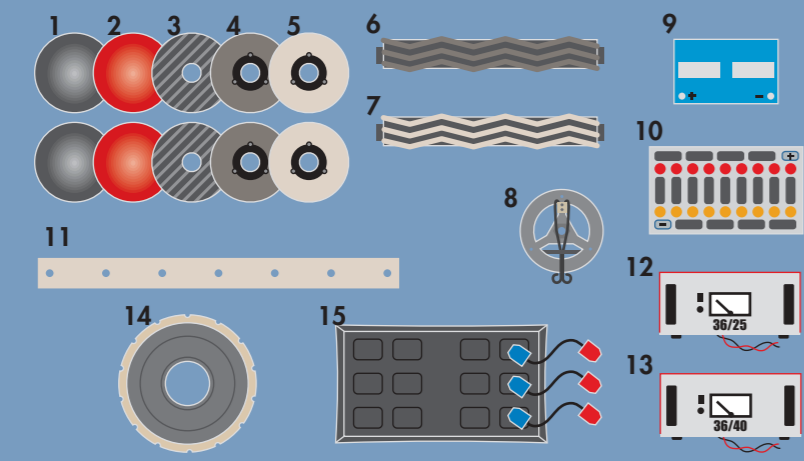

Dimensions

	A	B	C
JUMBO 812	1815	830	1430
JUMBO 872 R	1815	960	1430
JUMBO 962	1815	980	1430

Hourly cleaning performance

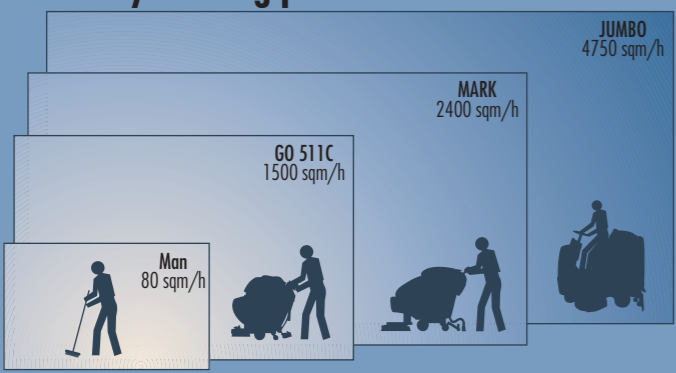

SWEEPERS - SCRUBBERS

RCM S.p.A.
via Tiraboschi, 4 - 41041 Casinalbo
Modena - Italia - Tel. +39 059 515 311
Fax +39 059 510 783
www.rcm.it - info@rcm.it

Click on www.rcm.it to discover immediately how you can save on your cleaning costs!

JUMBO

JUMBO is equipped with devices to improve its operation. Automatic raising of the squeegee when reverse gear selected, delayed suction cut-off in order **not to leave dirty water on the ground**, automatic cut-off and raising of the brushes a few seconds after the machine has stopped in order **not to damage the floor**, the gradual starting of the brushes and suction motor to **reduce energy consumption** and avoid high pressure, automatic cut-off of power to the brushes when the batteries are low.

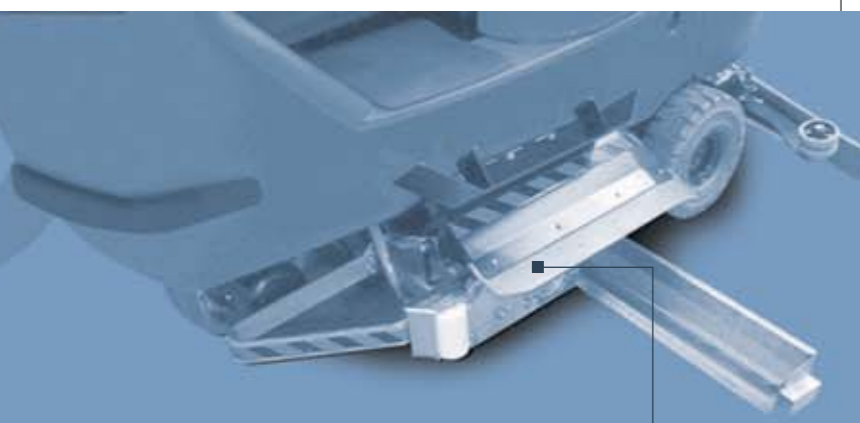

JUMBO 872 has a twin roller brush deck: it scrubs and simultaneously sweeps debris off the ground, storing it in a large container.

Roller brush deck

Electronic system

JUMBO has been certified according to ELECTROMAGNETIC COMPATIBILITY NORMS. All electronic components are kept inside a steel box under the seat, easy to reach yet **completely protected**.

JUMBO can be fitted with a larger 360A battery; this gives the machine a **working time of more than 4 hours** in standard conditions. The efficiency and life of the battery is governed by an **electronic control** which cuts out the brushes when a certain discharge is reached.

Battery housing

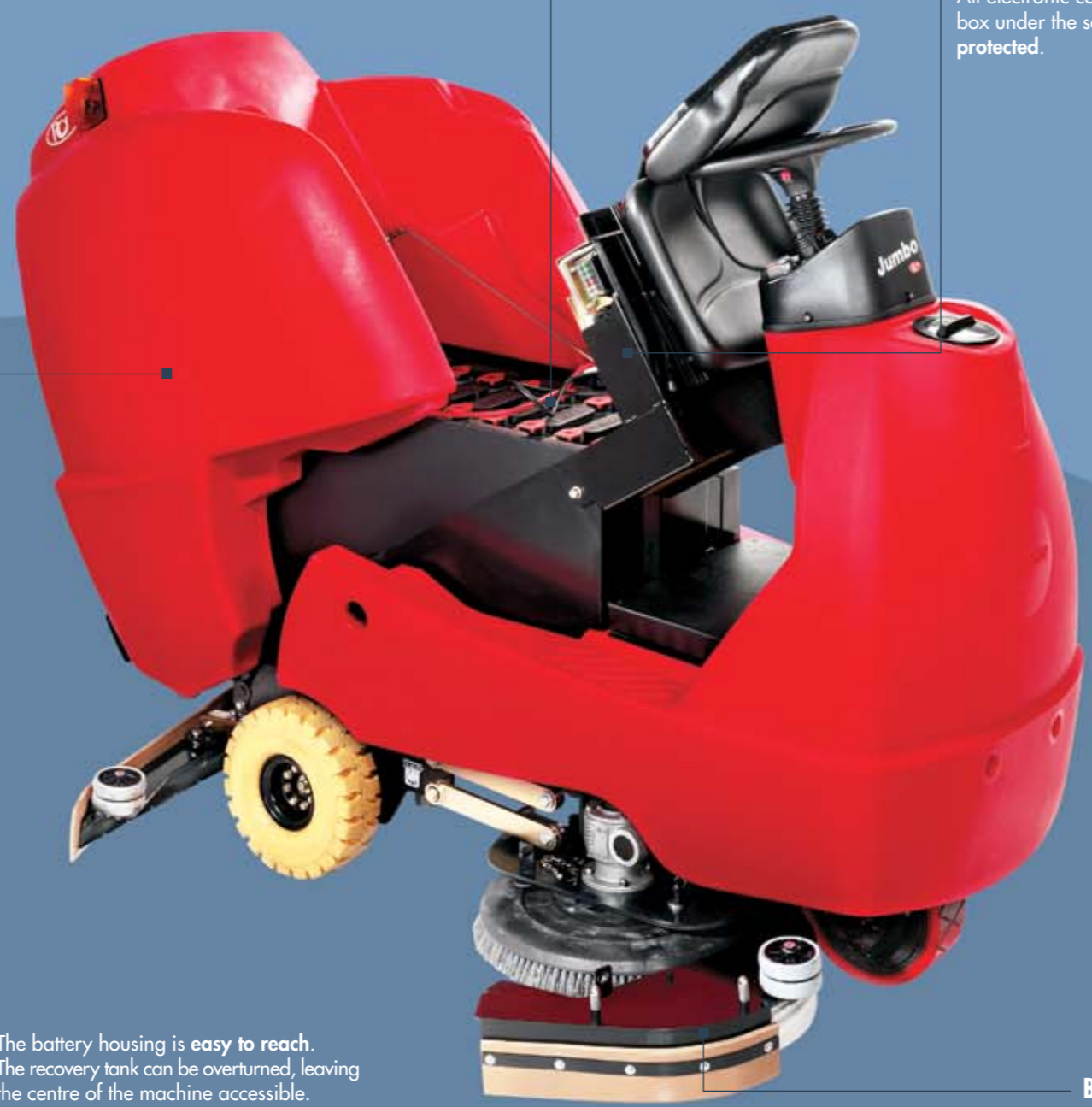

The battery housing is **easy to reach**. The recovery tank can be overturned, leaving the centre of the machine accessible.

Battery access and charging

Technical features

		812	872 R	962
Hourly cleaning performance	sqm/h	4000	4300	4750
Scrubbing width	mm	800	860	950
Drying width	mm	1100	1100	1100
Brushes (No./type)		2/disc	2/roller	2/disc
Solution tank capacity	lt	180	180	180
Recovery tank capacity	lt	195	195	195
Battery	V-Ah	36-360	36-360	36-360
Power	W	2700	2700	2700
Weight	Kg	365	365	377
Dimensions (length x width x height)	mm	1815x830x1430	1815x960x1430	1815x980x1430

Dashboard

A comfortable driving position and easy accessed controls are the basis to **working quickly without stress**. All information about machine operations are shown on the large display in the centre of the dashboard. The other lights are simply to warn of: empty solution tank, full recovery tank, raise and lower of brushes, gear and 3 speed selection, brush pressure, ignition and horn.



Brush deck

An electronic system controlled by the operator keeps the ground pressure on the brushes constant. **Changing the brushes is easy**, with 2 removable covers and the brush installment system, very simple and handy even when the machine is dirty.

Solution tank

It is easy to load the detergent solution (180 lt.) with the pipe provided or because the opening is big enough and easy to reach you can even use a bucket.



Squeegee

Just 110 cm. wide so as not to be too bulky and therefore able to dry even when working in the narrowest places. The rear rubber can be used on all four edges and can easily be changed without tools; the height and angle are also simple to adjust.

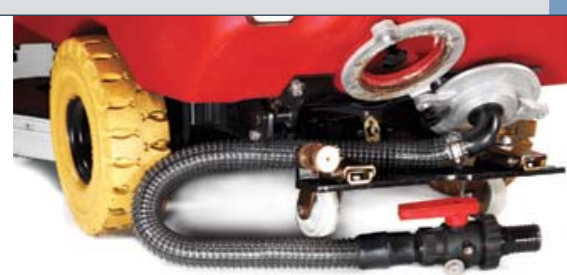

Recovery tank emptying

JUMBO is equipped with a valve to control the flow when emptying the tank. To clean any residue from the bottom of the tank simply take off the lid.



Suction motor/s

The suction motor is on top of the recovery tank, it is protected by water and foam and is very easy to remove. If required, an additional motor can be installed alongside the first to increase suction power.



Recovery tank filter

The aluminium cover can easily be opened to access the filter or to clean the tank.

Cleans large areas in a flash!